



Thermal Manufacturing Solutions

Section K

Instruments

**Programmable RTD Temperature
Transmitters—Series 440**

K-1

**Programmable temperature
Transmitters—Series 441**

K-5

Digital Thermometer DE-305

K-11

PROGRAMMABLE RTD TEMPERATURE TRANSMITTERS - SERIES 440

The Series 440 programmable RTD temperature transmitter is a two-wire transmitter with an analog output. It has measurement input for Pt100 resistance thermometers (RTD) in 2 or 3 wire connection. Setting up for the transmitter is done using the 440-CABLE. These small units can be mounted in Acrolab heads so they can be used for surface mounting by using a 35mm DIN rail mounting clip.

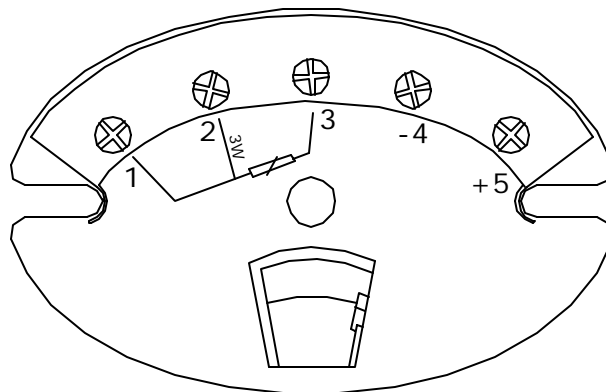

Application Areas

- PC programmable temperature transmitter for converting Pt100 input signal into a scaleable (4 to 20) mA analog output signal
- Platinum Resistance thermometer (RTD)
- Online configuration using PC with SETUP connector

Features and Benefits

- Universally PC programmable for Pt100 signals
- 2 wire technology, (4 to 20) mA analog output
- High accuracy in total ambient temperature range
- Fault signal on sensor break or short circuit
- RFI/EMI Protected, **CE** marked
- **UL** ^{us} UL Recognized Component
- **FM** **CS** General Purpose and non-incendive for use in hazardous locations
- Online configuration during measurement using SETUP connector

PROGRAMMABLE RTD TEMPERATURE TRANSMITTERS - SERIES 440

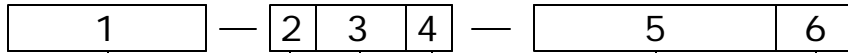

1. Series	
CODE	
440	

6. Temperature Scale	
CODE	DESCRIPTION
C	Celcius
F	Fahrenheit

2. Input	
CODE	DESCRIPTION
2	RTD (2-wire)
3	RTD (3-wire)

5. Temperature Range	
RANGE	
(lower limit - upper limit)	

3. RTD Style	
CODE	DESCRIPTION
85	100 ohm platinum ($\alpha=0.00385 \text{ } ^\circ\text{C}^{-1}$)

4. Burnout	
CODE	DESCRIPTION
U	Upscale Burnout $\geq 21.0 \text{ mA}$
D	Downscale Burnout $\leq 3.6 \text{ mA}$

Available Accessories	
CODE	DESCRIPTION
440-CABLE	Communication Cable and Software (RS232)
440-CABLE-USB	Communication Cable and Software (USB)
440-DIN35	35 mm DIN rail mounting clip

PROGRAMMABLE RTD TEMPERATURE TRANSMITTERS - SERIES 440

Resistance Thermometer Input (RTD)

TYPE	MEASUREMENT RANGE	MINIMUM RANGE
Pt100 ($\alpha = 0.00385^{\circ} \text{C}^{-1}$)	-200 to 650° C (-328 to 1202° F)	10°C (18°F)
Connection Type	2 or 3 wire cable resistance compensation possible in the 2 wire system (0 to 20) Ω	
Sensor cable resistance	maximum 11 Ω per cable	
Sensor current	$\leq 0.6 \text{ mA}$	

Output (Analog)

Output Signal	(4 to 20) mA or (20 to 4) mA
Transmission as	Temperature linear
Maximum Load	$(V_{\text{power supply}} - 10 \text{ V}) / 0.023 \text{ A}$ (current output)
Digital filters 1st degree	(0 to 8) s
Induced current required	$\leq 3.5 \text{ mA}$
Current limit	$\leq 23 \text{ mA}$
Switch on delay	4 s (during power 1 $I_{\text{z}} = 3.8 \text{ mA}$)
Electronic response time	1 s

Failure Mode

Undershooting measurement range	Decrease to 3.8mA
Exceeding measurement range	Increase to 20.5 mA
Sensor breakage/short circuit	$\leq 3.6 \text{ mA}$ or $\geq 21.0 \text{ mA}$

Electronic Connection

Power Supply	$U_b = (10 \text{ to } 30) \text{ V dc}$, polarity protected
Allowable ripple	$U_{\text{ss}} \leq 5 \text{ V}$ at $U_b \geq 13 \text{ V}$, $f_{\text{max}} = 1 \text{ kHz}$

Resistance Thermometer Accuracy (RTD)

TYPE	MEASUREMENT ACCURACY
Pt100	0.2° C or 0.08% ⁽¹⁾
Reference conditions	Calibration temperature: 23 $\pm 0.5^{\circ} \text{C}$ (73 $\pm 0.9^{\circ} \text{F}$)

General Accuracy

Influence of power supply	$\pm 0.01\% \text{ V}$ deviation from 24 V ⁽²⁾
Load influence	$\pm 0.02\% / 100 \Omega$ ⁽²⁾
Temperature drift	$T = (15 \text{ ppm}/^{\circ} \text{C} \times (\text{range end value} + 200) + 50 \text{ ppm}/^{\circ} \text{C} \times \text{measurement range}) \times \Delta\theta$ $\Delta\theta$ = deviation of the ambient temperature according to the reference condition $\Delta\theta$
Long term stability	$\leq 0.1^{\circ} \text{C}/\text{year}$ ⁽³⁾ or $\leq 0.05\%/\text{year}$ ⁽¹⁾⁽³⁾

(1) % is related to the adjusted measurement range (the value to be applied is the greater)

(2) All data is related to a measurement end value of 20 mA

(3) Under reference conditions

PROGRAMMABLE RTD TEMPERATURE TRANSMITTERS - SERIES 440

Environmental Conditions

Ambient temperature	-40 to 85° C (-40 to 185° F)
Storage temperature	-40 to 100° C (-40 to 212° F)
Climatic class	EN 60 654-1, Class C
Condensation	Permitted
Shock resistance	4 g / (2 to 150) Hz according to IEC 60 068-2-6
EMC immunity	Interference immunity and interference according to EN 61 326-1 (IEC 1326)

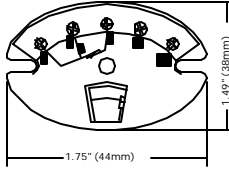

Mechanical Construction

Dimensions	
Weight	Approximately 44 g
Materials	Housing: Polycarbonate Potting: Polyurethane
Terminals	15 AWG (maximum)

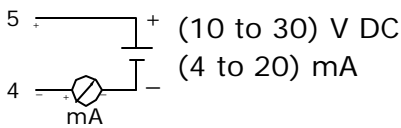
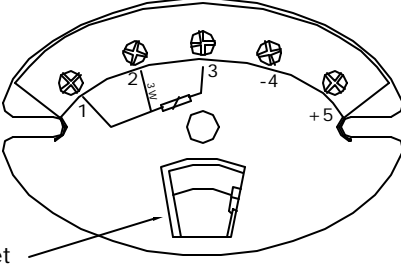
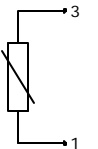
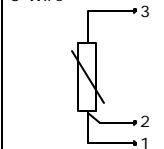
Terminal Connections

<p>Power supply and current output</p> 	
<p>2-Wire</p> 	
<p>3-Wire</p> 	

Approvals

  	<p>Unit complies with the legal requirements set forth by the EU regulations</p> <p>UL Recognized Component</p> <p>General Purpose and non-incendive for use in hazardous locations Class 1, Division 2 Groups A, B, C and D</p>
---	--

PROGRAMMABLE TEMPERATURE TRANSMITTERS - SERIES 441

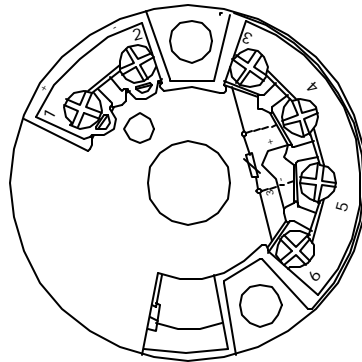

The Series 441 programmable RTD temperature transmitter is a two-wire transmitter with an analog output. It has measurement input for resistance thermometers (RTD) in 2, 3 or 4 wire connection, thermocouples, resistance and voltage. Setting up for the transmitter is done using the 440-CABLE. These small units can be mounted in Acrolab heads so they can be used for surface mounting by using a 35mm DIN rail mounting clip.



Application Areas

- PC programmable temperature transmitter for converting various input signals into a scaleable (4 to 20) mA analog output signal
- Input
 - Resistance thermometer (RTD)
 - Thermocouple (TC)
 - Resistance (Ω)
 - Voltage (mV)
- Online configuration using PC with SETUP connector

Features and Benefits

- Universally PC programmable for various signals
- Galvanic isolation
- 2 wire technology, (4 to 20) mA analog output
- High accuracy in total ambient temperature range
- Fault signal on sensor break or short circuit
- RFI/EMI Protected, CE marked
-  UL Recognized Component
-  Intrinsically safe and non-incendive for hazardous locations
- Online configuration during measurement using SETUP connector
- Online simulation

PROGRAMMABLE TEMPERATURE TRANSMITTERS - SERIES 441



1. Series

CODE
441

2. Input

CODE	DESCRIPTION
1	Thermocouple (TC)
2	RTD (2-wire)
3	RTD (3-wire)
4	RTD (4-wire)

3. Calibration

CODE	DESCRIPTION
J	Type J thermocouple
K	Type K thermocouple
T	Type T thermocouple
N	Type N thermocouple
E	Type E thermocouple
R	Type R thermocouple
S	Type S thermocouple
B	Type B thermocouple
85	100 ohm platinum (a=0.00385 °C-1)
55	500 ohm platinum (a=0.00385 °C-1)
95	1000 ohm platinum (a=0.00385 °C-1)
MV	Millivolts
W	Resistance

6. Temperature Scale

CODE	DESCRIPTION
C	Celcius
F	Fahrenheit

5. Temperature Range

RANGE
(lower limit - upper limit)

4. Burnout

CODE	DESCRIPTION
U	Upscale Burnout ≥ 21.0 mA
D	Downscale Burnout ≤ 3.6 mA

Available Accessories

CODE	DESCRIPTION
440-CABLE	Communication Cable and Software (RS232)
440-CABLE-USB	Communication Cable and Software (USB)
440-DIN35	35 mm DIN rail mounting clip

PROGRAMMABLE TEMPERATURE TRANSMITTERS - SERIES 441

Input

Resistance Thermometer (RTD)

TYPE	MEASUREMENT RANGE	MINIMUM RANGE
Pt100 ($\alpha = 0.00385^{\circ}\text{C}^{-1}$) ⁽¹⁾	-200 to 850° C (-328 to 1562° F)	10° C (18° F)
Pt500	-200 to 250° C (-328 to 482° F)	10° C (18° F)
Pt1000	-200 to 250° C (-328 to 482° F)	10° C (18° F)
Ni100 ($\alpha = 0.00618^{\circ}\text{C}^{-1}$) ⁽¹⁾	-60 to 180° C (-76 to 356° F)	10° C (18° F)
Ni500	-60 to 150° C (-76 to 302° F)	10° C (18° F)
Ni1000	-60 to 150° C (-76 to 302° F)	10° C (18° F)
Connection Type	2, 3 or 4 wire connection cable resistance compensation possible in the 2 wire system (0 to 20) Ω	
Sensor Cable Resistance	maximum 11 Ω per cable	
Sensor Current	≤ 0.6 mA	

Resistance (Ω)

TYPE	MEASUREMENT RANGE	MINIMUM RANGE
Resistance	10 to 400 Ω	10 Ω
	10 to 2000 Ω	100 Ω

Thermocouple (TC)

TYPE	MEASUREMENT RANGE	MINIMUM RANGE
B	0 to 1820° C (32 to 3308° F)	500° C (900° F)
C	0 to 2320° C (32 to 4208° F)	500° C (900° F)
D ⁽³⁾	0 to 2495° C (32 to 4523° F)	500° C (900° F)
E	-200 to 915° C (-328 to 1679° F)	50° C (90° F)
J	-200 to 1200° C (-328 to 2192° F)	50° C (90° F)
K	-200 to 1372° C (-328 to 2501° F)	50° C (90° F)
L ⁽²⁾	-200 to 900° C (-328 to 1652° F)	50° C (90° F)
N	-270 to 1300° C (-454 to 2372° F)	50° C (90° F)
R	0 to 1768° C (32 to 3214° F)	500° C (900° F)
S	0 to 1768° C (32 to 3214° F)	500° C (900° F)
T	-200 to 400° C (-328 to 752° F)	50° C (90° F)
U ⁽²⁾	-200 to 600° C (-328 to 1112° F)	50° C (90° F)
MoRe5-MoRe4 ⁽¹⁾	0 to 2000° C (32 to 3632° F)	500° C (900° F)

Voltage (mV)

TYPE	MEASUREMENT RANGE	MINIMUM RANGE
Millivolt (mV)	-10 to 100 mV	5 mV

(1) no reference

(2) according to DIN 43710

(3) according to ASTM E988

PROGRAMMABLE TEMPERATURE TRANSMITTERS - SERIES 441

Output

Output (Analog)

Output signal	4 to 20 mA or 20 to 4 mA
Transmission as	Temperature linear, resistance linear, voltage linear
Maximum load	$(V_{\text{power supply}} - 8 \text{ V}) / 0.025 \text{ A}$ (current output)
Digital filter 1st degree	0 to 8 s
Induced current required	$\leq 3.5 \text{ mA}$
Current limit	$\leq 25 \text{ mA}$
Switch on delay	4 s (during power up $I_{\text{sc}} = 3.8 \text{ mA}$)
Electronic response time	1 s

Failure Mode

Undershooting measurement range	4 to 20 mA or 20 to 4 mA
Exceeding measurement range	Temperature linear, resistance linear, voltage linear
Sensor breakage/short circuit ⁽¹⁾	$\leq 3.5 \text{ mA}$ or $\geq 1.0 \text{ mA}$

Failure Mode

Power Supply	$U_{\text{I}} = (8 \text{ to } 30) \text{ V dc}$, polarity protected
Galvanic Isolation (in/out)	$\hat{U} = 3.75 \text{ kV ac}$
Allowable ripple	$U_{\text{r}} \leq 5 \text{ V}$ at $U_{\text{I}} \geq 13 \text{ V}$, $f \leq 1 \text{ kHz}$

Accuracy

Output (Analog)

Reference conditions	Calibration temperature: $23 \pm 0.5^\circ \text{ C}$ ($73 \pm 0.9^\circ \text{ F}$)
----------------------	--

Resistance Thermometer (RTD)

TYPE	MEASUREMENT ACCURACY
Pt100, Ni100	0.2° C or 0.08% ■
Pt500, Ni500	0.5° C or 0.20% ■
Pt1000, Ni1000	0.3° C or 0.12% ■

Resistance (Ω)

TYPE	MEASUREMENT RANGE	MINIMUM RANGE
Resistance	0.1Ω or 0.08% ⁽²⁾	10 to 400Ω
	1.5Ω or 0.12% ⁽²⁾	10 to 2000Ω

(1) not for thermocouple

(2) % is related to the adjusted measurement range (the value to be applied is the greater)

PROGRAMMABLE TEMPERATURE TRANSMITTERS - SERIES 441

Accuracy (continued)

Thermocouple (TC)

TYPE	MEASUREMENT ACCURACY
E, J, K, L, T, U	0.5° C or 0.08% ⁽¹⁾
C, D, N	1.0° C or 0.08% ⁽¹⁾
B, MoRe5-MoRe41, R, S	2.0° C or 0.08% ⁽¹⁾
Influence of the internal junction	Pt100 $\pm 0.30 + 0.005 t $ ° C t = value of temperature without regard to sign ° C

Voltage (mV)

TYPE	MEASUREMENT RANGE	MINIMUM RANGE
Millivolt (mV)	$\pm 20 \mu\text{V}$ or 0.08% ⁽¹⁾	-10 to 100 mV

General

Influence of power supply	$\pm 0.01\%/V$ deviation from 24 V ⁽²⁾
Load influence	$\pm 0.02\%/100 \Omega$ ⁽²⁾
Temperature drift	Resistive thermometer (RTD): $T_d = \pm(15 \text{ ppm}/^\circ\text{C} \times \text{range end value} + 50 \text{ ppm}/^\circ\text{C} \times \text{measurement range})$ $\Delta\Phi$
	Resistive thermometer Pt100: $T_d = \pm(15 \text{ ppm}/^\circ\text{C} \times (\text{range end value} + 200) + 50 \text{ ppm}/^\circ\text{C} \times \text{measurement range})$ $\Delta\Phi$
	Thermocouple (TC) $T_d = \pm(50 \text{ ppm}/^\circ\text{C} \times \text{range end value} + 50 \text{ ppm}/^\circ\text{C} \times \text{measurement range})$ $\Delta\Phi$
Load influence	$\Delta\Phi$ = Deviation of the ambient temperature according to the reference condition
Long Term Stability	$\leq 0.1^\circ\text{C}/\text{year}$ ⁽³⁾ or $\leq 0.05\%/ \text{year}$ ⁽¹⁾⁽³⁾

Installation Conditions

Environmental Conditions

Ambient temperature	-40 to 85° C (-40 to 185° F)
Storage temperature	-40 to 100° C (-40 to 212° F)
Climatic class	EN 60 654-1, Class C
Moisture condensation	Allowable
Vibration resistance	4 g / (2 to 150) Hz according to IEC 60 068-2-6
EMC immunity	Interference immunity and interference according to EN 61 326-1 (IEC 1326)

(1) % is related to the adjusted measurement range (the value to be applied is the greater)

(2) All data is related to a measurement end value of 20 mA

(3) Under reference conditions

PROGRAMMABLE TEMPERATURE TRANSMITTERS - SERIES 441

Mechanical Construction

Mechanical Construction

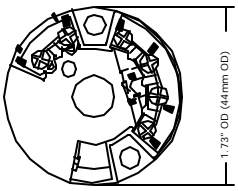
Dimensions	
Weight	Approximately 40 g
Materials	Housing: Polycarbonate Potting: Polyurethane
Terminals	15 AWG (maximum)

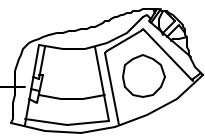
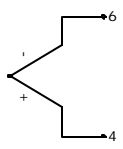
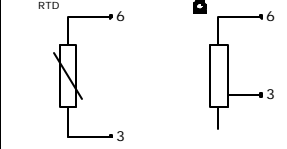
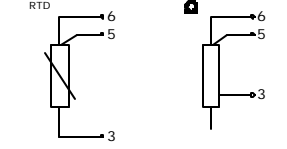
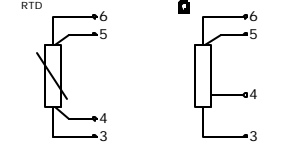

Terminal Connections

<p>Power supply and current output</p> <p>2 — (8 to 30) V DC 1 — (4 to 20) mA</p>	 <p>SETUP socket</p>		
<p>Thermocouple</p> 	<p>2-Wire RTD</p> 	<p>3-Wire RTD</p> 	<p>4-Wire RTD</p> 

Remote Operations

Configuration set	Configuration kit 440-CABLE
Configuration	Using PC program TransComm
Interface	PC interface connection cable TTL +/- RS 232 with plug
Configuration parameters	Sensor type and connection type, engineering units (°C/°F), measurement range, internal/external cold junction compensation, cable resistance compensation on 2 wire connection, fault conditioning, output signal 4 to 20 mA or 20 to 4 mA, digital filter (damping), offset, measurement point identification (8 characters), output simulation.

Approvals

  	<p>Unit complies with the legal requirements set forth by the EU regulations</p> <p>UL Recognized Component</p> <p>Intrinsically safe and non-incendive for use in hazardous locations Class 1, Division 2 Groups A, B, C and D</p>
---	---

DIGITAL THERMOMETER DE-305

Specifications

Technical

Temperature scale: °C or °F User-Selective.

Resolution: 1°C or 1°F (or 0.1°C or 0.1°F)

User-Selectable

Inputs: One K-type Thermocouple

Measurement Range: 50 ~ 1300°C, (-59 ~ 2000°F)

Meter Operating Range: For Using at 0°C ~ 50°C Environment (32 ~ 122°F)

Accuracy: (18~28°C ambient)

±(0.3 %rdg + 1°C) -50 ~ 1000°C

±(0.5 %rdg + 1°C) 1000 ~ 1300°C

±(0.3 %rdg + 2°C) -58 ~ 2000°C

The accuracy specification does not include type D thermocouple probe accuracy.

Temperature Coefficient: 0.1 times the applicable accuracy specification per °C from 0°C to 18°C to 50°C

Error Offset: Errors contributed by one particular thermocouple may be practically eliminated, over a limited measurement range, using a recessed front panel OFFSET adjust on the meter and an accurate standard when making the adjustment. Although making the adjustment may increase errors for using different thermocouples

Maximum Input: 60V dc or 24V rms ac between the input pins or any input and ground.

General

Display: 3 1/2 digit liquid crystal display (LCD) with maximum reading of 1999.

Sampling Rate: 2.5 times per second

Battery: One 9V battery (6F 22)

Dimensions (mm): 148(H)x71(W)x36(D)

Weight: 208g (including battery)

Power Current: Approx. DC 2.8mA (typical)

Enclosure

1. Manual 2. Battery 9V 3. Rubber Holster

Accessories for Customer Option

1. NR-31B 2. NR-33 3. NR-34

4. NR-39 5. NR-34-INCO

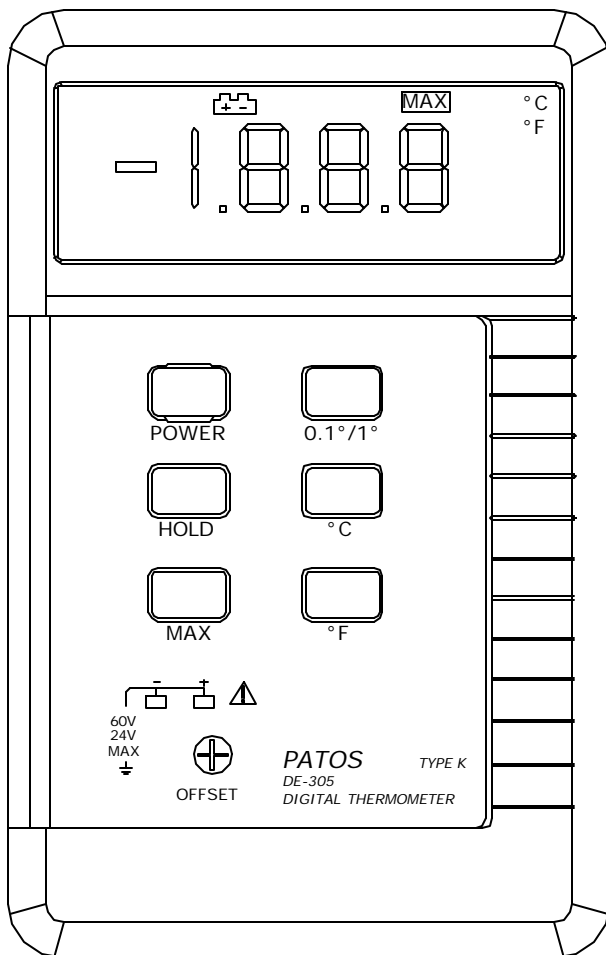

DE-305 Digital Thermometer

- Large size LCD indication
- Low Battery Indication
- K-Type Thermocouple (option)
- Handheld Lightweight Design
- Reading Hold Function
- Maximum Record
- °C or °F Annunciators Display
- 1°C or 0.1°C (1°F or 0.1°F)
- °C °F switchable on front panel
- Single Thermocouple Input
- User-Selectable Resolution
- Front Panel Offset Adjustment