



Thermal Manufacturing Solutions

Section E

Explosion Proof Thermocouples and RTDs

Fixed Element RTD Assemblies	E-1
Element Thermocouple Assemblies	E-3
RTD Assemblies With Thermowells	E-5
Thermocouple Assemblies With Thermowells	E-7
Spring Loaded RTD Assemblies	E-9
Spring Loaded Thermocouple Assemblies	E-11
Temperature Transmitters for Explosion Proof Assemblies	E-13
Connecting Head And Transmitter Selection Guide	E-14
Overview Of NEC Hazardous Location Classifications And Methods Of Protection	E-15

EXPLOSION PROOF APPROVED FIXED ELEMENT RTD ASSEMBLIES - MODEL 70-22

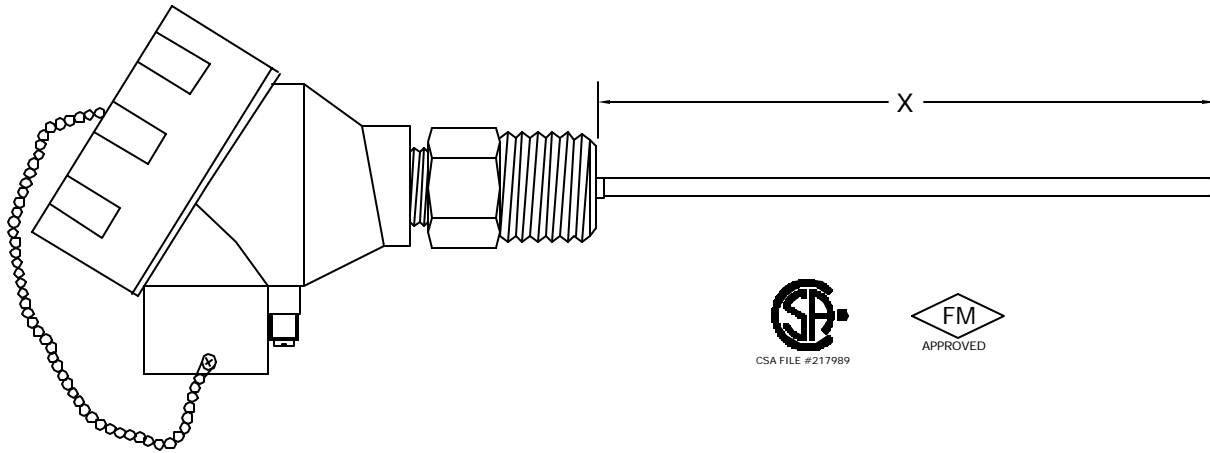

Explosion Proof Fixed Element RTD's are for use in U.S. and Canadian hazardous areas. They are designed to extinguish flames inside the device eliminating the potential for ignition of ammable mixtures in the surrounding atmosphere. FM and CSA approved assemblies, dependent on connection head type, meet XP Class I, Division 1, Group A, B, C and D; DIP Class II, Division I, Groups E, F, G, and Class III, Division 1. They may be installed directly in the process without being inserted into a thermowell. The assemblies feature 316 stainless steel sheaths in various diameter sizes. They are available with or without process mountings and with aluminum or stainless steel explosion proof connection heads.

EXPLOSION PROOF APPROVED FIXED ELEMENT RTD ASSEMBLIES - MODEL 70-22

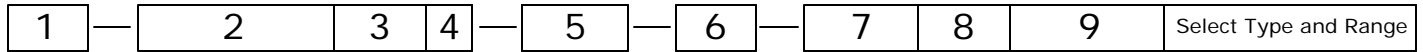

1. AGENCY APPROVAL	
CODE	DESCRIPTION
XP	FM/CSA explosion proof approved assembly

2. 100 Ohm PLATINUM RTD ELEMENTS		
CODE		INITIAL ELEMENT ACCURACY 0°C
LOW RANGE WIRE WOUND (-200 TO 204)°C		
SINGLE	DUPLEX	
R1T185L	R1T285L	±0.1%
R5T185L	R5T285L	±0.01%
LOW RANGE THIN FILM (-40 to 204)°C		
RBF185L	RBF285L	±0.12%
RAF185L	RAF285L	±0.06%
HIGH RANGE WIRE WOUND (-200 TO 600)°C		
R1T185H	R1T285H	±0.1%

3. SHEATH DIAMETERS	
CODE	DIAMETER (inches)
28*	1/8 *Not available in Duplex
38	3/16
48	1/4
68	3/8

4. ELEMENT CONNECTION	
CODE	DIAMETER (inches)
2	2 Wire Element
3	3 Wire Element
4*	4 Wire Element *(Not Avail. in Duplex or with 440 Series Transmitter)

9. OPTIONS	
CODE	DESCRIPTION
SB	1/2" NPT conduit reducer bushing
I	Stainless steel tag
T-440*	(4 to 20) mA heat-mounted transmitter
T-441**	(4 to 20) mA isolated heat-mounted transmitter
T-442**	(4 to 20) mA HART® isolated heat-mounted transmitter

*Only available with option 71 or 81
**Not available with option 71 or 81

8. HEAD TERMINATIONS	
CODE	DESCRIPTION
71	Cast iron/aluminum explosion proof head Group C
72	DIN form B aluminum explosion proof head Group B
74	DIN form B aluminum explosion proof head Group A
75T-642B	(4 to 20) mA HART® Field Transmitter with aluminum explosion proof housing, Group A
81	316L stainless steel explosion proof head Group C
82	DIN form B 316 stainless steel explosion proof head Group B

7. HEAD MOUNTING FITTINGS	
CODE	DESCRIPTION
6HN	1/2" x 1/2" NPT hex nipple 1" "E" length
8HN	1/2" x 1/2" NPT hex nipple 1" "E" length
9HP	1/2" NPT stainless steel bushing (no process threads)
8RNDC	3/4" x 1/2" NPT stainless steel hex nipple

6. SHEATH MOUNTING FITTINGS	
CODE	DESCRIPTION
00	No Fitting

5. "X" DIMENSIONS	
Insert three digit sheath length ("X" Dimension) in inches	

EXPLOSION PROOF APPROVED FIXED ELEMENT THERMOCOUPLE ASSEMBLIES - MODEL 70-82

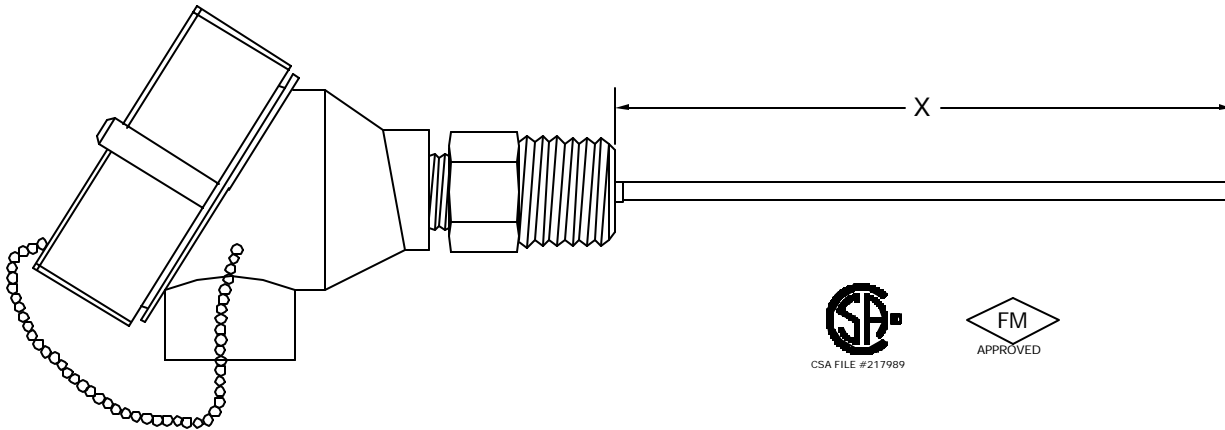

Explosion Proof Fixed Element Thermocouples are for use in U.S. and Canadian hazardous areas. They are designed to extinguish flames inside the device eliminating the potential for ignition of flammable mixtures in the surrounding atmosphere. FM and CSA approved assemblies, dependant on connection head type, meet XP Class I, Division 1, Group A, B, C and D; DIP Class II, Division I, Groups E, F, G and Class III, Division 1. They may be installed directly in the process without being inserted into a thermowell. The assemblies feature 316 stainless steel sheaths in various diameter sizes and ungrounded isolated junctions. They are available with or without process mountings and with aluminum or stainless steel explosion proof connection heads.

EXPLOSION PROOF APPROVED FIXED ELEMENT THERMOCOUPLE ASSEMBLIES - MODEL 70-82

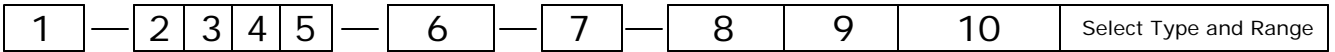

1. AGENCY APPROVAL	
CODE	DESCRIPTION
XP	FM/CSA explosion proof approved assembly

2. THERMOCOUPLE TYPES	
CODE	DESCRIPTION
SINGLE	DUPLEX
E	EE
J	JJ
K	KK
T	TT

3. SHEATH DIAMETERS	
CODE	DIAMETER (inches)
2	1/8
38	3/16
4	1/4
6	3/8

4. SHEATH MATERIALS		
CODE	MATERIAL	STANDARD AVAILABLE TYPES
3	Inconel 600	J, K
4	310 SS	K
5	446 SS	K
8	316 SS	E, J, K, T

5. MEASURING JUNCTION	
CODE	DESCRIPTION
U	Ungrounded

10. OPTIONS	
CODE	DESCRIPTION
SB	1/2" NPT conduit reducer bushing
I	Stainless steel tag
T-441*	(4 to 20) mA isolated heat-mounted transmitter
T-442*	(4 to 20) mA HART® isolated heat-mounted transmitter

*Not available with option 71 or 81

9. HEAD TERMINATIONS	
CODE	DESCRIPTION
71	Cast iron/aluminum explosion proof head Group C
72	DIN form B aluminum explosion proof head Group B
74	DIN form B aluminum explosion proof head Group A
75T-642B	(4 to 20) mA HART® Field Transmitter with aluminum explosion proof housing, Group A
81	316L stainless steel explosion proof head Group C
82	DIN form B 316 stainless steel explosion proof head Group B

8. HEAD MOUNTING FITTINGS	
CODE	DESCRIPTION
6HN	1/2" x 1/2" NPT hex nipple 1" "E" length
8HN	1/2" x 1/2" NPT stainless steel hex nipple 1" "E" length
9HP	1/2" NPT stainless steel bushing (no process threads)
8RNDC	3/4" x 1/2" NPT stainless steel hex nipple

7. SHEATH MOUNTING FITTINGS	
CODE	DESCRIPTION
00	No Fitting

6. "X" DIMENSIONS	
Insert three digit sheath length ("X" Dimension) in inches	

EXPLOSION PROOF APPROVED RTD ASSEMBLIES WITH THERMOWELLS - MODEL 70-20

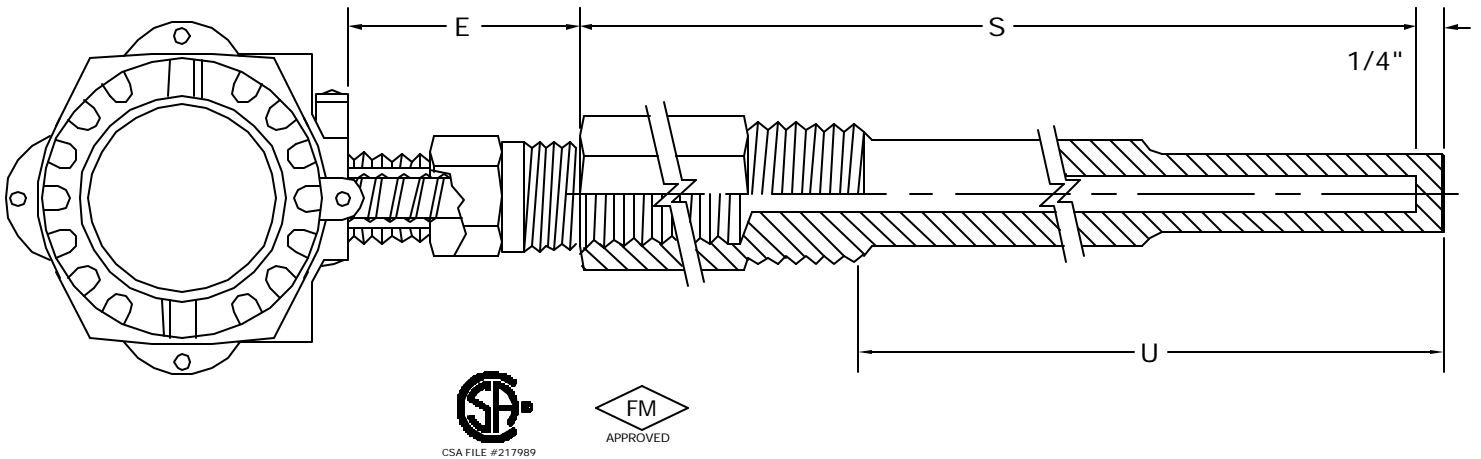

Explosion Proof RTD Assemblies with Thermowells are for use in U.S. and Canadian hazardous areas. They are designed to extinguish flames inside the device eliminating the potential for ignition of flammable mixtures in the surrounding atmosphere. FM and CSA approved assemblies, dependant on connection head type, meet XP Class I, Division 1, Group A, B, C, and D; DIP Class II, Division I, Groups E, F, G and Class III, Division 1. The required thermowell is available in standard, heavy-duty, and flanged constructions. The assemblies feature 316 stainless steel sheaths. They are available with aluminum or stainless steel explosion proof connection heads.

EXPLOSION PROOF APPROVED

RTD ASSEMBLIES WITH THERMOWELLS - MODEL 70-20

1	2	3	4	5	6	7	8	9	Select Type and Range
---	---	---	---	---	---	---	---	---	-----------------------

1. AGENCY APPROVAL

CODE	DESCRIPTION
XP	FM/CSA explosion proof approved assembly

2. 100 Ohm PLATINUM RTD ELEMENTS

CODE	INITIAL ELEMENT ACCURACY 0°C	
LOW RANGE WIRE WOUND (-200 TO 204)°C		
SINGLE	DUPLEX	
R1T185L	R1T285L	±0.1%
R5T185L	R5T285L	±0.01%
LOW RANGE THIN FILM (-40 to 204)°C		
RBF185L	RBF285L	±0.12%
RAF185L	RAF285L	±0.06%
HIGH RANGE WIRE WOUND (-200 TO 600)°C		
R1T185H	R1T285H	±0.1%

3. SHEATH DIAMETERS 316 S.S.

CODE	DIAMETER (inches)
48	1/4

4. ELEMENT CONNECTION

CODE	DIAMETER (inches)
2	2 Wire Element
3	3 Wire Element
4*	4 Wire Element *(Not Avail. in Duplex or with 440 Series Transmitter)

5. THERMOWELL

Select thermowell part number from Thermowell Section

6. ELEMENT OPTIONS

CODE	DIAMETER (inches)
SL*	Spring loaded element
SC	Self-contained spring loaded element

*Not available with option 75T-642B

9. OPTIONS

CODE	DESCRIPTION
SB	1/2" NPT conduit reducer bushing
I	Stainless steel tag
T-440*	(4 to 20) mA heat-mounted transmitter
T-441**	(4 to 20) mA isolated heat-mounted transmitter
T-442**	(4 to 20) mA HART® isolated heat-mounted transmitter

*Only available with option 71 or 81
**Not available with option 71 or 81

8. HEAD TERMINATIONS

CODE	DESCRIPTION
71	Cast iron/aluminum explosion proof head Group C
72	DIN form B aluminum explosion proof head Group B
74	DIN form B aluminum explosion proof head Group A
75T-642B	(4 to 20) mA HART® Field Transmitter with aluminum explosion proof housing, Group A
81	316L stainless steel explosion proof head Group C
82	DIN form B 316 stainless steel explosion proof head Group B

7. HEAD MOUNTING FITTINGS

CODE	DESCRIPTION
STEEL FITTINGS	
6HN	1/2" x 1/2" NPT hex nipple 1" length
6PN_	1/2" x 1/2" NPT pipe nipple (specify "E" length in inches)
6XU_*	1/2" x 1/2" NPT union/nipple (specify "E" length in inches)
316SS FITTINGS	
8HN	1/2" x 1/2" NPT hex nipple 1" length
8PN	1/2" x 1/2" NPT pipe nipple (specify "E" length in inches)
8XU_*	1/2" x 1/2" NPT union/nipple (specify "E" length in inches)

*3 1/2" Minimum length required. Maximum allowable "E" is 9".

EXPLOSION PROOF APPROVED THERMOCOUPLE ASSEMBLIES WITH THERMOWELLS - MODEL 70-80

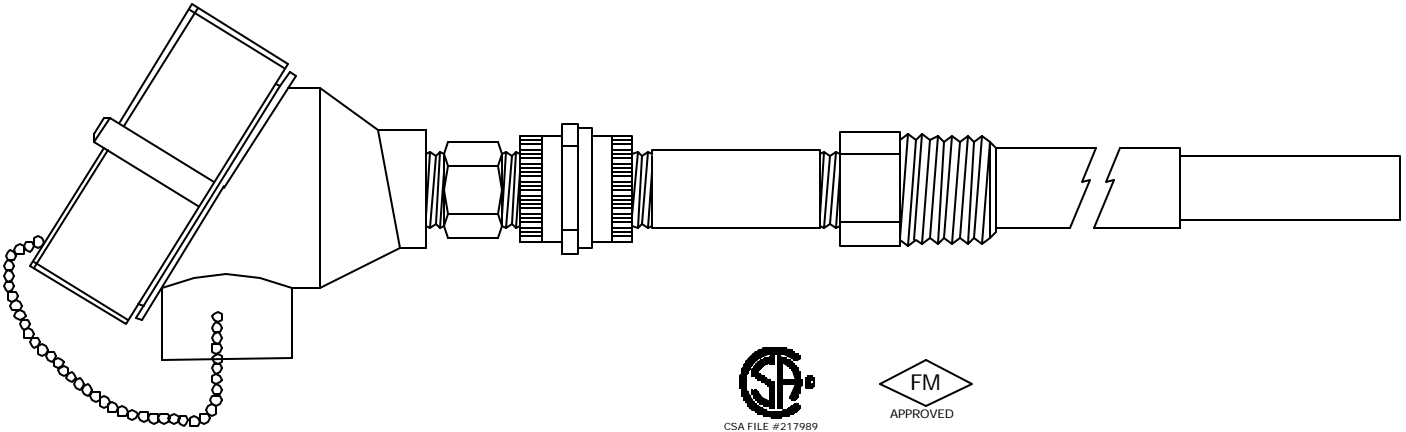

Explosion Proof RTD Assemblies with Thermowells are for use in U.S. and Canadian hazardous areas. They are designed to extinguish flames inside the device eliminating the potential for ignition of flammable mixtures in the surrounding atmosphere. FM and CSA approved assemblies, dependant on connection head type, meet XP Class I, Division 1, Group A, B, C, and D; DIP Class II, Division I, Groups E, F, G and Class III, Division 1. The required thermowell is available in standard, heavy-duty, and flanged constructions. The assemblies feature 316 stainless steel sheaths and ungrounded isolated junctions. They are available with aluminum or stainless steel explosion proof connection heads.

EXPLOSION PROOF APPROVED THERMOCOUPLE ASSEMBLIES WITH THERMOWELLS - MODEL 70-80

1	2	3	4	5 Select Thermowell Part # from Thermowell Section	6	7	8	9	Select Type and Range
---	---	---	---	---	---	---	---	---	-----------------------

1. AGENCY APPROVAL	
CODE	DESCRIPTION
XP	FM/CSA explosion proof approved assembly

2. THERMOCOUPLE TYPES	
CODE	DESCRIPTION
SINGLE	DUPLEX
E	EE
J	JJ
K	KK
T	TT

3. SHEATH DIAMETERS 316 S.S.	
CODE	DIAMETER (inches)
48	1/4

4. MEASURING JUNCTION	
CODE	DESCRIPTION
U	Ungrounded

5. THERMOWELL	
Select thermowell part number from Thermowell Section	

6. ELEMENT OPTIONS	
CODE	DIAMETER (inches)
SL*	Spring loaded element
SC	Self-contained spring loaded element
*Not available with option 75T-642B	

9. OPTIONS	
CODE	DESCRIPTION
SB	1/2" NPT conduit reducer bushing
I	Stainless steel tag
T-441*	(4 to 20) mA isolated heat-mounted transmitter
T-442*	(4 to 20) mA HART® isolated heat-mounted transmitter
*Not available with option 71 or 81	

8. HEAD TERMINATIONS	
CODE	DESCRIPTION
71	Cast iron/aluminum explosion proof head Group C
72	DIN form B aluminum explosion proof head Group B
74	DIN form B aluminum explosion proof head Group A
75T-642B	(4 to 20) mA HART® Field Transmitter with aluminum explosion proof housing, Group A
81	316L stainless steel explosion proof head Group C
82	DIN form B 316 stainless steel explosion proof head Group B

7. HEAD MOUNTING FITTINGS	
CODE	DESCRIPTION
STEEL FITTINGS	
6HN	1/2" x 1/2" NPT hex nipple 1" length
6PN_	1/2" x 1/2" NPT pipe nipple (specify "E" length in inches)
6XU_*	1/2" x 1/2" NPT union/nipple (specify "E" length in inches)
316SS FITTINGS	
8HN	1/2" x 1/2" NPT hex nipple 1" length
8PN	1/2" x 1/2" NPT pipe nipple (specify "E" length in inches)
8XU_*	1/2" x 1/2" NPT union/nipple (specify "E" length in inches)
*3 1/2" Minimum length required. Maximum allowable "E" is 9".	

EXPLOSION PROOF APPROVED SPRING LOADED RTD ASSEMBLIES - MODEL 70-21

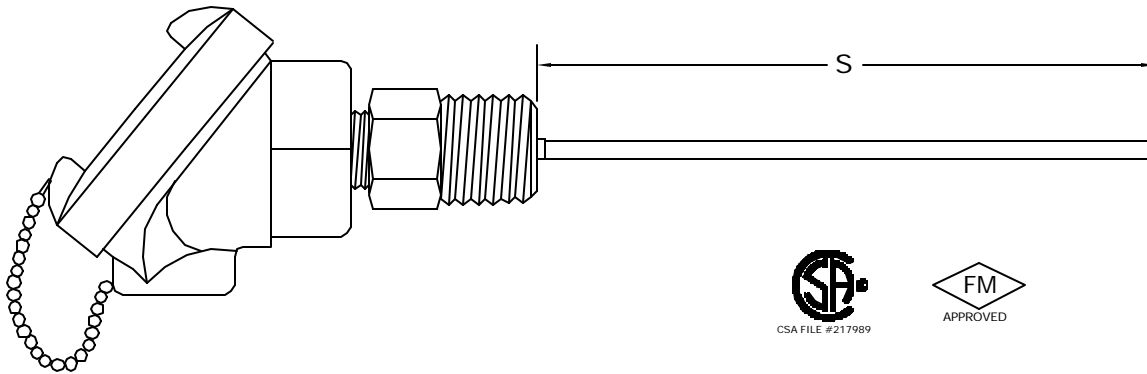

Explosion Proof Spring-Loaded RTD's are for use in U.S. and Canadian hazardous areas. They are designed to extinguish flames inside the device eliminating the potential for ignition of flammable mixtures in the surrounding atmosphere. FM and CSA approved assemblies, dependant on connection head type, meet XP Class I, Division 1, Group B, C and D; DIP Class II, Division I, Groups E, F, G and Class III, Division 1. Pyromation provides sensors for installation into your existing thermowell or provides the required thermowell as part of the assembly. Refer to the Thermowell Section of this catalog for product selection. The assemblies feature 316 stainless steel sheaths. They are available with aluminum or stainless steel explosion proof connection heads. **Note:** The "S" dimension will measure 1/4" longer than specified when the spring is in the relaxed position. The "S" dimension is calculated when the sensor is compressed or in the installed position. This design allows 1/4" spring compression to ensure positive contact with the bottom of the thermowell.

EXPLOSION PROOF APPROVED

SPRING LOADED RTD ASSEMBLIES - MODEL 70-21

WITH INTEGRAL FLAME PATH

1	2	3	4	5	6	7	8	9	Select Type and Range
---	---	---	---	---	---	---	---	---	-----------------------

1. AGENCY APPROVAL	
CODE	DESCRIPTION
XP	FM/CSA explosion proof approved assembly

2. 100 Ohm PLATINUM RTD ELEMENTS		
CODE	INITIAL ELEMENT ACCURACY 0°C	
LOW RANGE WIRE WOUND (-200 TO 204)°C		
SINGLE	DUPLEX	
R1T185L	R1T285L	±0.1%
R5T185L	R5T285L	±0.01%
LOW RANGE THIN FILM (-40 to 204)°C		
RBF185L	RBF285L	±0.12%
RAF185L	RAF285L	±0.06%
HIGH RANGE WIRE WOUND (-200 TO 600)°C		
R1T185H	R1T285H	±0.1%

3. SHEATH DIAMETERS 316 S.S.	
CODE	DIAMETER (inches)
48	1/4

4. ELEMENT CONNECTION	
CODE	DIAMETER (inches)
2	2 Wire Element
3	3 Wire Element
4*	4 Wire Element *(Not Avail. in Duplex or with 440 Series Transmitter)

9. OPTIONS	
CODE	DESCRIPTION
SB	1/2" NPT conduit reducer bushing
I	Stainless steel tag
T-440*	(4 to 20) mA heat-mounted transmitter
T-441**	(4 to 20) mA isolated heat-mounted transmitter
T-442**	(4 to 20) mA HART® isolated heat-mounted transmitter
*Only available with option 71 or 81	
**Not available with option 71 or 81	

8. HEAD TERMINATIONS	
CODE	DESCRIPTION
71	Cast iron/aluminum explosion proof head Group C
72	DIN form B aluminum explosion proof head Group B
75T-642D	(4 to 20) mA HART® Field Transmitter with aluminum explosion proof housing, Group A
81	316L stainless steel explosion proof head Group C
82	DIN form B 316 stainless steel explosion proof head Group B

7. HEAD MOUNTING FITTINGS	
CODE	DESCRIPTION
316 STAINLESS STEEL FITTINGS	
8HN	1/2" x 1/2" NPT hex nipple 1" length
8PU4*	1/2" x 1/2" NPT pipe nipple w/ flame path(specify "E" in inches)
*For longer lengths replace "4" with length in inches.	

6. ELEMENT OPTIONS	
FP	DESCRIPTION
FP	Spring loaded element with flame path

5. "S" DIMENSIONS	
Insert three digit sheath length ("S" Dimension) in inches	

EXPLOSION PROOF APPROVED SPRING LOADED THERMOCOUPLE ASSEMBLIES - MODEL 70-81

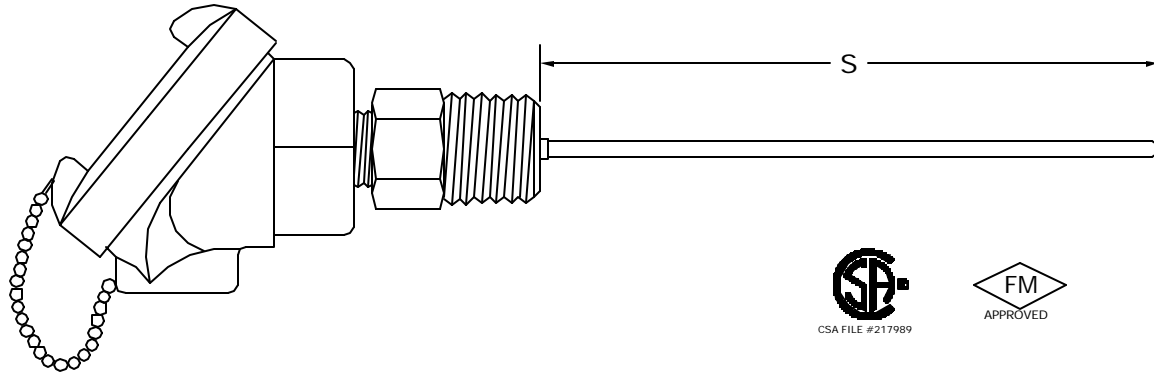

Explosion Proof Spring-Loaded Thermocouples are for use in U.S. and Canadian hazardous areas. They are designed to extinguish flames inside the device eliminating the potential for ignition of flammable mixtures in the surrounding atmosphere. FM and CSA approved assemblies, dependant on connection head type, meet XP Class I, Division 1, Group B, C and D; DIP Class II, Division I, Groups E, F, G and Class III, Division 1. Pyromation provides sensors for installation into your existing thermowell or provides the required thermowell as part of the assembly. Refer to the Thermowell Section of this catalog for product selection. The assemblies feature 316 stainless steel sheaths and ungrounded isolated junctions. They are available with aluminum or stainless steel explosion proof connection heads. **Note:** The "S" dimension will measure 1/4" longer than specified when the spring is in the relaxed position. The "S" dimension is calculated when the sensor is compressed or in the installed position. This design allows 1/4" spring compression to ensure positive contact with the bottom of the thermowell.

EXPLOSION PROOF APPROVED SPRING LOADED THERMOCOUPLE ASSEMBLIES - MODEL 70-81 WITH INTEGRAL FLAME PATH

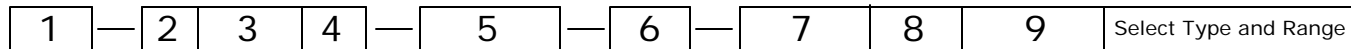

1. AGENCY APPROVAL	
CODE	DESCRIPTION
XP	FM/CSA explosion proof approved assembly

2. THERMOCOUPLE TYPES	
CODE	DESCRIPTION
SINGLE	DUPLEX
E	EE
J	JJ
K	KK
T	TT

3. SHEATH DIAMETERS 316 S.S.	
CODE	DIAMETER (inches)
48	1/4

4. MEASURING JUNCTION	
CODE	DESCRIPTION
U	Ungrounded

5. "S" DIMENSIONS	
Insert three digit sheath length ("S" Dimension) in inches	

9. OPTIONS	
CODE	DESCRIPTION
SB	1/2" NPT conduit reducer bushing
I	Stainless steel tag
T-440*	(4 to 20) mA heat-mounted transmitter
T-441**	(4 to 20) mA isolated heat-mounted transmitter
T-442**	(4 to 20) mA HART® isolated heat-mounted transmitter
*Only available with option 71 or 81	
**Not available with option 71 or 81	

8. HEAD TERMINATIONS	
CODE	DESCRIPTION
71	Cast iron/aluminum explosion proof head Group C
72	DIN form B aluminum explosion proof head Group B
75T-642D	(4 to 20) mA HART® Field Transmitter with aluminum explosion proof housing, Group A
81	316L stainless steel explosion proof head Group C
82	DIN form B 316 stainless steel explosion proof head Group B

7. HEAD MOUNTING FITTINGS	
CODE	DESCRIPTION
316 STAINLESS STEEL FITTINGS	
8HN	1/2" x 1/2" NPT hex nipple 1" length
8PU4*	1/2" x 1/2" NPT pipe nipple w/ flame path(specify "E" in inches)
*For longer lengths replace "4" with length in inches.	

6. ELEMENT OPTIONS	
CODE	DESCRIPTION
FP	Spring loaded element with flame path

TEMPERATURE TRANSMITTERS FOR EXPLOSION PROOF SENSOR ASSEMBLIES

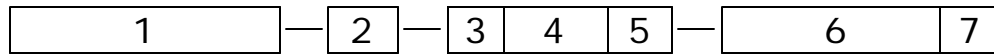

1. TRANSMITTER TYPE	
CODE	DESCRIPTION
T-440*	(4 to 20) mA heat-mounted transmitter
T-441	(4 to 20) mA isolated heat-mounted transmitter
T-442	(4 to 20) mA HART® isolated heat-mounted transmitter
75T-642B	(4 to 20) mA HART® Field Transmitter with aluminum explosion proof housing FM/CSA Class I, Div I, Groups A, B, C, D; Class II, Groups E, F, G; Class III
75T-642D	(4 to 20) mA HART® Field Transmitter with aluminum explosion proof housing FM/CSA Class I, Div I, Groups A, B, C, D; Class II, Groups E, F, G; Class III

*Only available with 2 or 3 wire input connection and Pt100 sensor type.

2. OPTIONS (FOR 642 SERIES ONLY)	
CODE	DESCRIPTION
T	Solid cover
D	Glass cover with digital display

*Leave blank if using 440, 441, or 442

3. INPUT TYPE	
CODE	DESCRIPTION
00*	Unconfigured
1	Thermocouple (TC)
2	RTD (2-wire)
3	RTD (3-wire)
4	RTD (4-wire)

*Default setting supplied as Pt100 (0-100)°C

7. UNIT OF MEASURE	
CODE	DESCRIPTION
C	Celcius
F	Fahrenheit

6. RANGE	
CODE	DESCRIPTION
S	(lower limit - upper limit)

5. FAILURE MODE	
CODE	DESCRIPTION
U	Upscale Burnout ≥ 20.5 mA
D	Downscale Burnout ≤ 3.8 mA

4. SENSOR TYPE	
CODE	DESCRIPTION
J	Type J thermocouple
K	Type K thermocouple
T	Type T thermocouple
N	Type N thermocouple
E	Type E thermocouple
85	100 ohm platinum ($\alpha = 0.00385^\circ\text{C}$)

OVERVIEW OF NEC[®] HAZARDOUS LOCATION CLASSIFICATIONS AND METHODS OF PROTECTION

CLASSES	GROUPS	DIVISIONS	
Class I	Examples	1	2
Location in which flammable gases or vapours are or may be present in the air in quantities sufficient to produce explosive or ignitable mixtures	Group A: Acetylene Group B: Hydrogen Group C: Ethylene Group D: Propane, Fuels, Solvents	Locations where hazardous material exists under normal operating conditions or through breakdown or repair.	Locations where hazardous materials are expected to be confined within closed containers of closed systems but may become present through a leak or process failure.
Class II	Examples		
Locations that are hazardous because of the presence of combustable dust.	Group E: Metal Dusts Group F: Carbon Dust Group G: Combustible Dust, Flour, Grain, Wood, Plastic, Chemicals	Combustible dust is in the air under normal operating conditions in quantities sufficient to produce explosive or ignitable mixtures or through breakdown or repair.	Combustible dust may be in the air in sufficient quantities to produce an explosion due to abnormal operations or failure of electrical equipment.
Class III	Examples		
Locations that are hazardous because of the presence of easily ignitable fibers or flyings are not likely to be in suspension in the air in quantities sufficient to produce ignitable mixtures.	There are no defined groups. Examples are Textiles, Woodworking, Paper Fibers.	Easily ignitable fibers or material producing combustible flyings are handled, manufactured or used.	Easily ignitable fibers are stored or handled other than in the process of manufacture.

METHODS OF PROTECTION			
Explosion Proof (XP) Class I, Division 1, 2	Dust-Ignitable (DIP) Class II, Division 1, 2	Dust-Ignitable (DIP) Class II, Division 1, 2 Class II, Division 1, 2 Class III, Division 1, 2	Nonincendive (NI) Class II, Division 2 Class II, Division 2 Class III, Division 1, 2
Apparatus enclosed in a case that is capable of withstanding an explosion of a specified gas or vapour that may occur within it and of preventing the ignition of a specified gas or vapour within, and that operates at such an external temperature that a surrounding flammable atmosphere will not be ignited thereby.	Equipment enclosed in a manner that excludes dust and does not permit arcs, sparks or heat otherwise generated or liberated inside of the enclosure to cause ignition of exterior accumulations or atmospheric suspensions of a external temperature that a specified dust on or in the vicinity of the enclosure.	Equipment not capable of releasing sufficient electrical or thermal energy under normal conditions to cause ignition of a specific flammable or combustable atmospheric mixture at its most easily ignitable concentration.	Equipment having electrical circuitry that is incapable, under normal operating conditions, of causing ignition of a specified flammable gas-air, ignition of a specified gas or vapour vapour-air or dust-air mixture due to arcing or thermal means.