

EXPLOSION PROOF APPROVED THERMOCOUPLE ASSEMBLIES WITH THERMOWELLS - MODEL 70-80

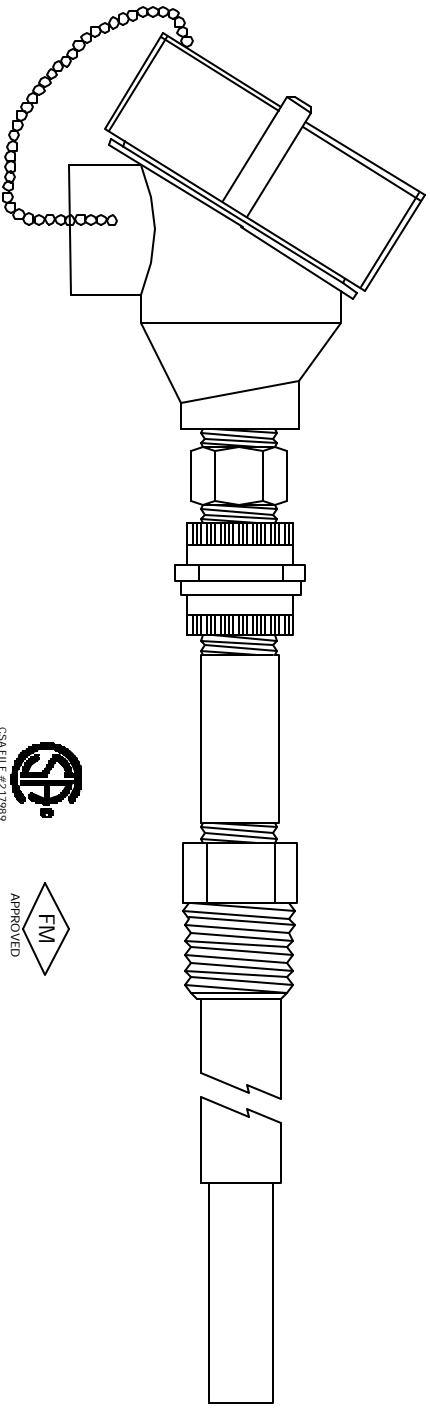

Explosion Proof RTD Assemblies with Thermowells are for use in U.S. and Canadian hazardous areas. They are designed to extinguish flames inside the device eliminating the potential for ignition of flammable mixtures in the surrounding atmosphere. FM and CSA approved assemblies, dependant on connection head type, meet XP Class I, Division 1, Group A, B, C, and D; DIP Class II, Division I, Groups E, F, G and Class III, Division 1. The required thermowell is available in standard, heavy-duty, and flanged constructions. The assemblies feature 316 stainless steel sheaths and ungrounded isolated junctions. They are available with aluminum or stainless steel explosion proof connection heads.