

EXPLOSION PROOF APPROVED SPRING LOADED THERMOCOUPLE ASSEMBLIES - MODEL 70-81

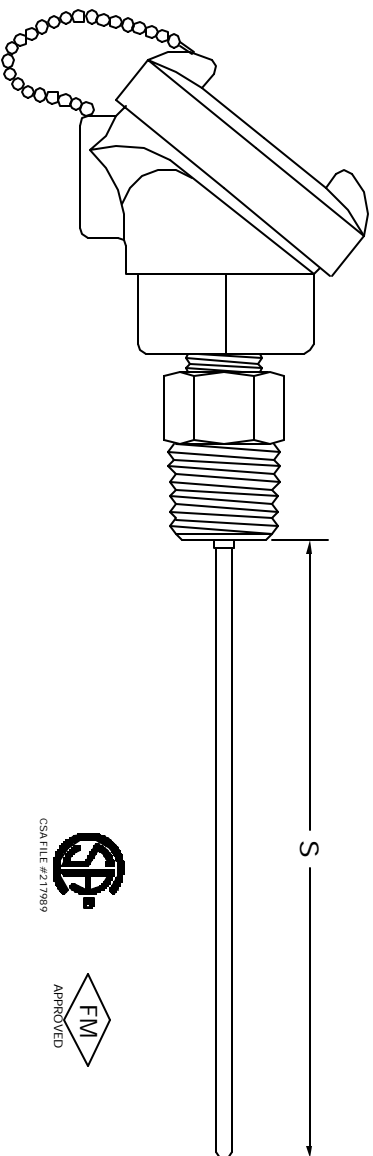

Explosion Proof Spring-Loaded Thermocouples are for use in U.S. and Canadian hazardous areas. They are designed to extinguish flames inside the device eliminating the potential for ignition of flammable mixtures in the surrounding atmosphere. FM and CSA approved assemblies, dependant on connection head type, meet XP Class I, Division 1, Group B, C and D; DIP Class II, Division I, Groups E, F, G and Class III, Division 1. Pyromation provides sensors for installation into your existing thermowell or provides the required thermowell as part of the assembly. Refer to the Thermowell Section of this catalog for product selection. The assemblies feature 316 stainless steel sheaths and ungrounded isolated junctions. They are available with aluminum or stainless steel explosion proof connection heads. **Note:** The "S" dimension will measure 1/4" longer than specified when the spring is in the relaxed position. The "S" dimension is calculated when the sensor is compressed or in the installed position. This design allows 1/4" spring compression to ensure positive contact with the bottom of the thermowell.