

EXPLOSION PROOF APPROVED FIXED ELEMENT RTD ASSEMBLIES - MODEL 70-22

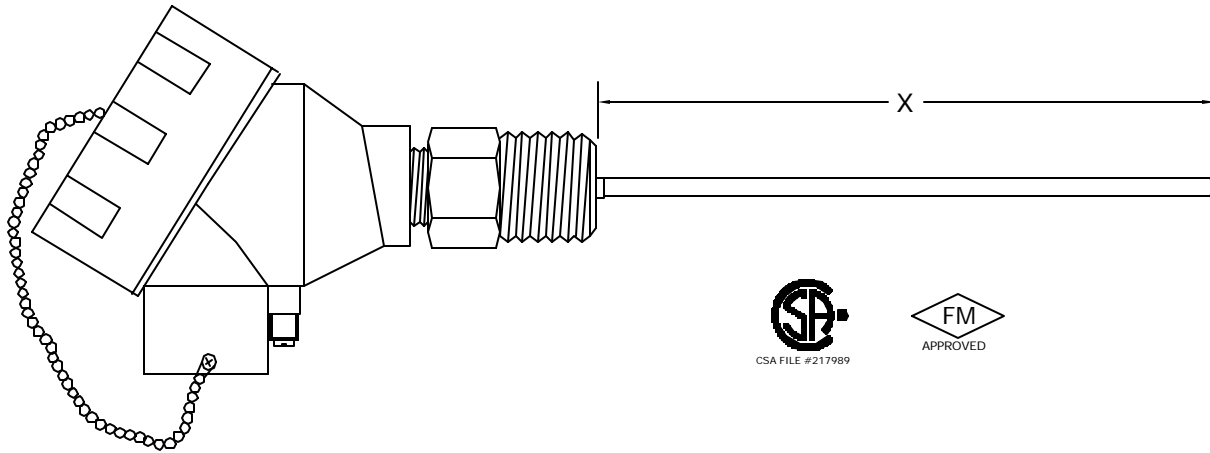

Explosion Proof Fixed Element RTD's are for use in U.S. and Canadian hazardous areas. They are designed to extinguish flames inside the device eliminating the potential for ignition of ammable mixtures in the surrounding atmosphere. FM and CSA approved assemblies, dependent on connection head type, meet XP Class I, Division 1, Group A, B, C and D; DIP Class II, Division I, Groups E, F, G, and Class III, Division 1. They may be installed directly in the process without being inserted into a thermowell. The assemblies feature 316 stainless steel sheaths in various diameter sizes. They are available with or without process mountings and with aluminum or stainless steel explosion proof connection heads.